



Wiring your SmartThermostat Pro to relays



Contractor support: Registration, account settings, equipment compatibility, wiring, etc.

Hours: M-F 8a-10p & Sa-Su 9a-9p

Phone: 866.518.6740 (Contractor assistance only)

Website: www.heatinggreen.com

208 OR 240 VOLT HEATER WIRING OPTIONS USING 20 AMP RELAY

1. The maximum number of heaters per circuit is limited to circuit wiring and the contact rating of the relay. Always refer to electric radiant ceiling heat panel manufacturer's specifications and wiring diagrams. Wiring diagrams are also available on line at <http://www.heatinggreen.com/thermostat-instructions-wiring-diagrams>
2. The RIBT24P relay contacts are rated at 20 Amps under 300 Volts and 15 Amps over 300 Volts.
3. Always use a properly grounded junction box when splicing.
4. Install only in a location where the power supply connections will be accessible.
5. Install junction box as far above panel as possible and above building insulation where present.
6. Use field wiring suitable for 194° F (90° C) if junction box is allowed to lie on heater or is enclosed between heater and ceiling above.
7. When installed in a drop ceiling, the wiring terminals should be accessible through removable ceiling sections with adequate clearance to permit access to the top of the heater.

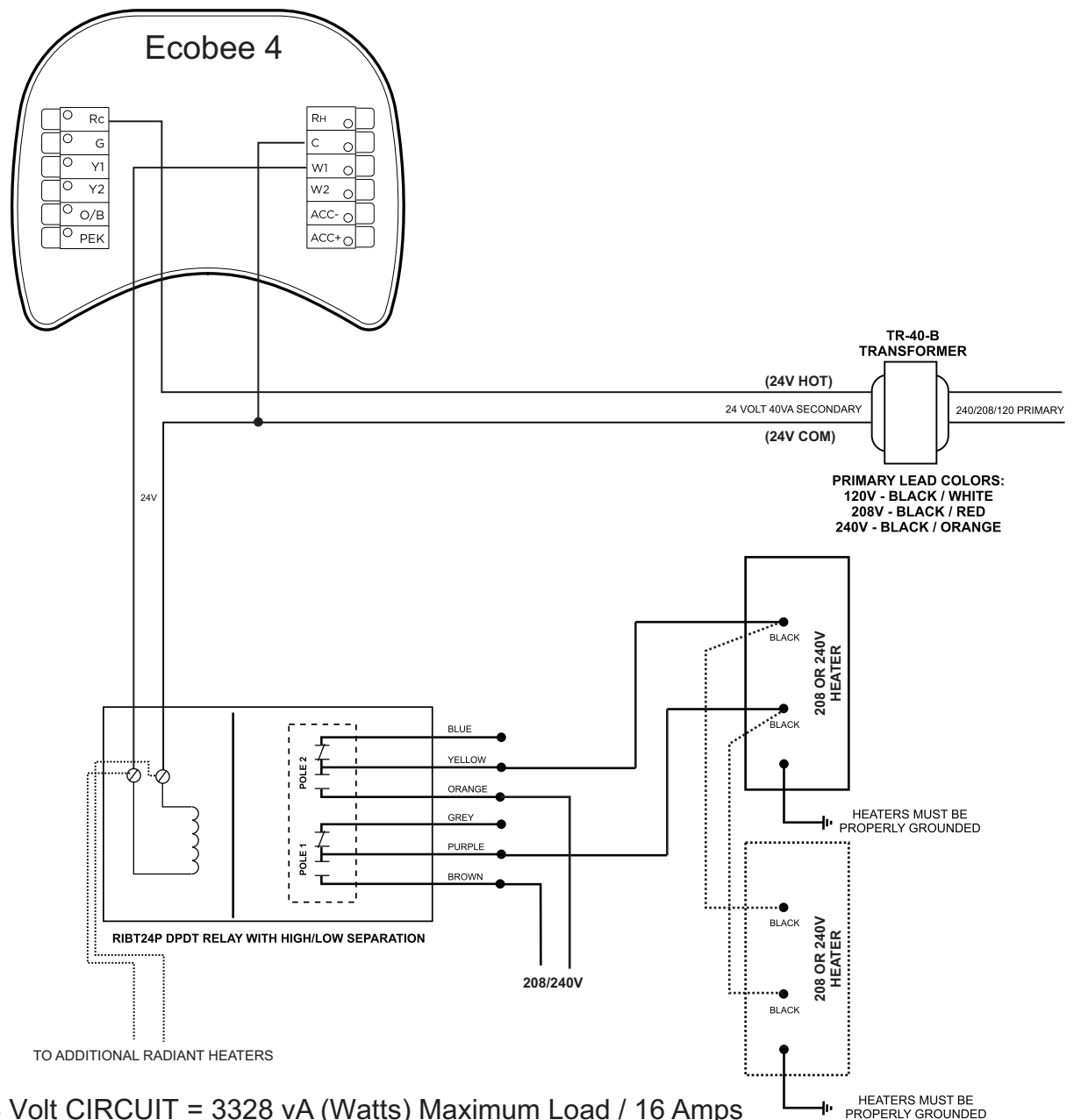

NOTE: 208 Volt CIRCUIT = 3328 vA (Watts) Maximum Load / 16 Amps
240 Volt CIRCUIT = 3840 vA (Watts) Maximum Load / 16 Amps

TYPICALLY 2-4 HEATERS FIT PER CIRCUIT, DEPENDING ON THE MODEL. PLEASE REFERENCE THE SPECIFICATIONS OF MODEL QUOTED FOR THE PROJECT TO MAKE THIS DETERMINATION.

120, 277 OR 347 VOLT HEATER WIRING OPTIONS USING 20 AMP RELAY

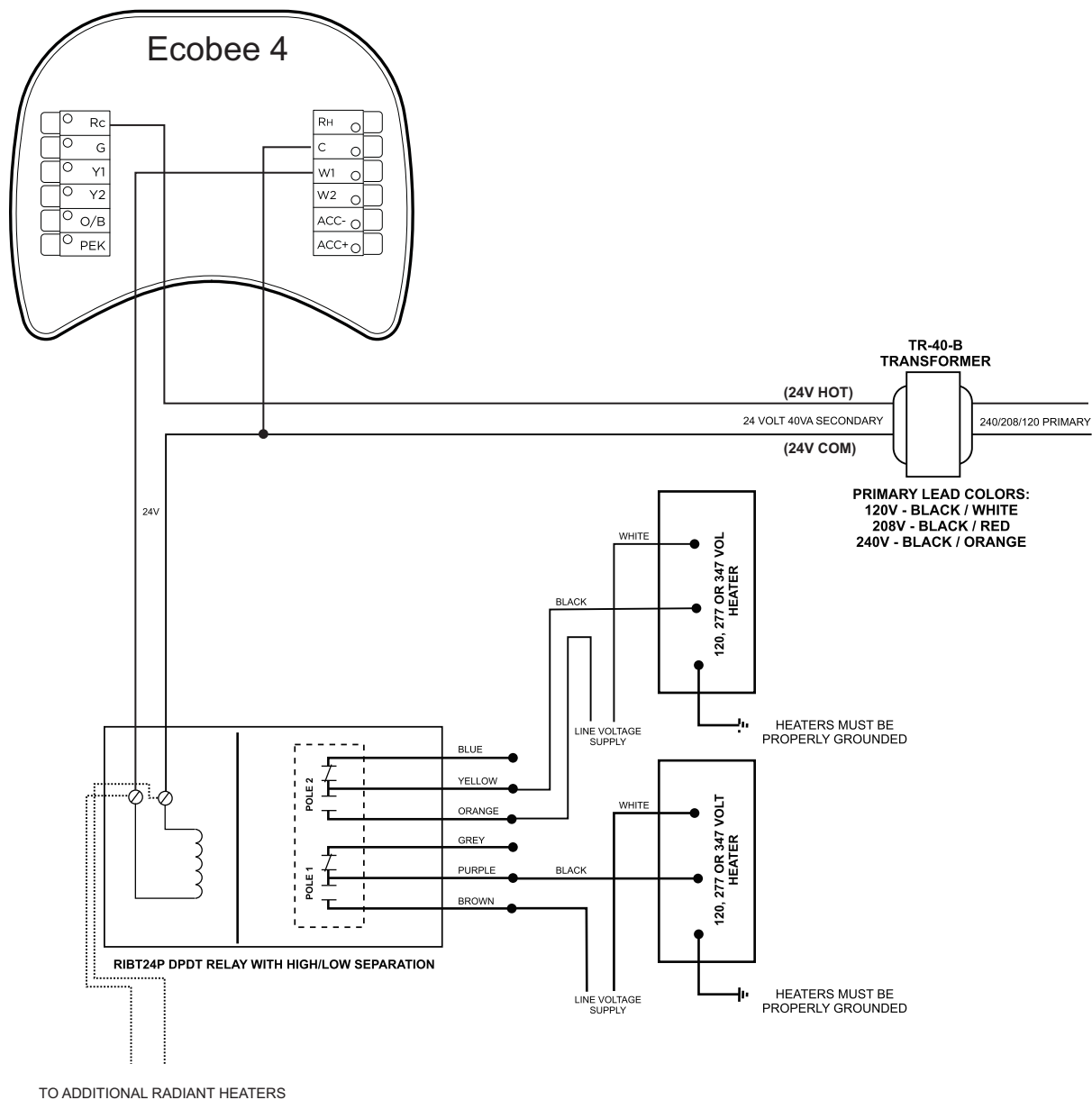

NOTE:

120 Volt CIRCUIT= 1920 vA (Watts) Maximum Load / 16 Amps
 277 Volt CIRCUIT = 4432 vA (Watts) Maximum Load / 16 Amps
 347 Volt CIRCUIT= 5552 vA (Watts) Maximum Load / 16 Amps

TYPICALLY 2-4 HEATERS FIT PER CIRCUIT, DEPENDING ON THE MODEL. PLEASE REFERENCE THE SPECIFICATIONS OF MODEL QUOTED FOR THE PROJECT TO MAKE THIS DETERMINATION.

120, 277,347 VOLT HEATER WIRING OPTIONS USING 30 AMP RELAY

1. The maximum number of heaters per circuit is limited to circuit wiring and the contact rating of the relay. Always refer to electric radiant ceiling heat panel manufacturer's specifications and wiring diagrams. Wiring diagrams are also available on line at <http://www.heatinggreen.com/thermostat-instructions-wiring-diagrams>
2. The RIBT24P30 relay contacts are rated at 30 Amps @ 300 Volts.
3. Always use a properly grounded junction box when splicing.
4. Install only in a location where the power supply connections will be accessible.
5. Install junction box as far above panel as possible and above building insulation where present.
6. Use field wiring suitable for 194° F (90° C) if junction box is allowed to lie on heater or is enclosed between heater and ceiling above.
7. When installed in a drop ceiling, the wiring terminals should be accessible through removable ceiling sections with adequate clearance to permit access to the top of the heater.

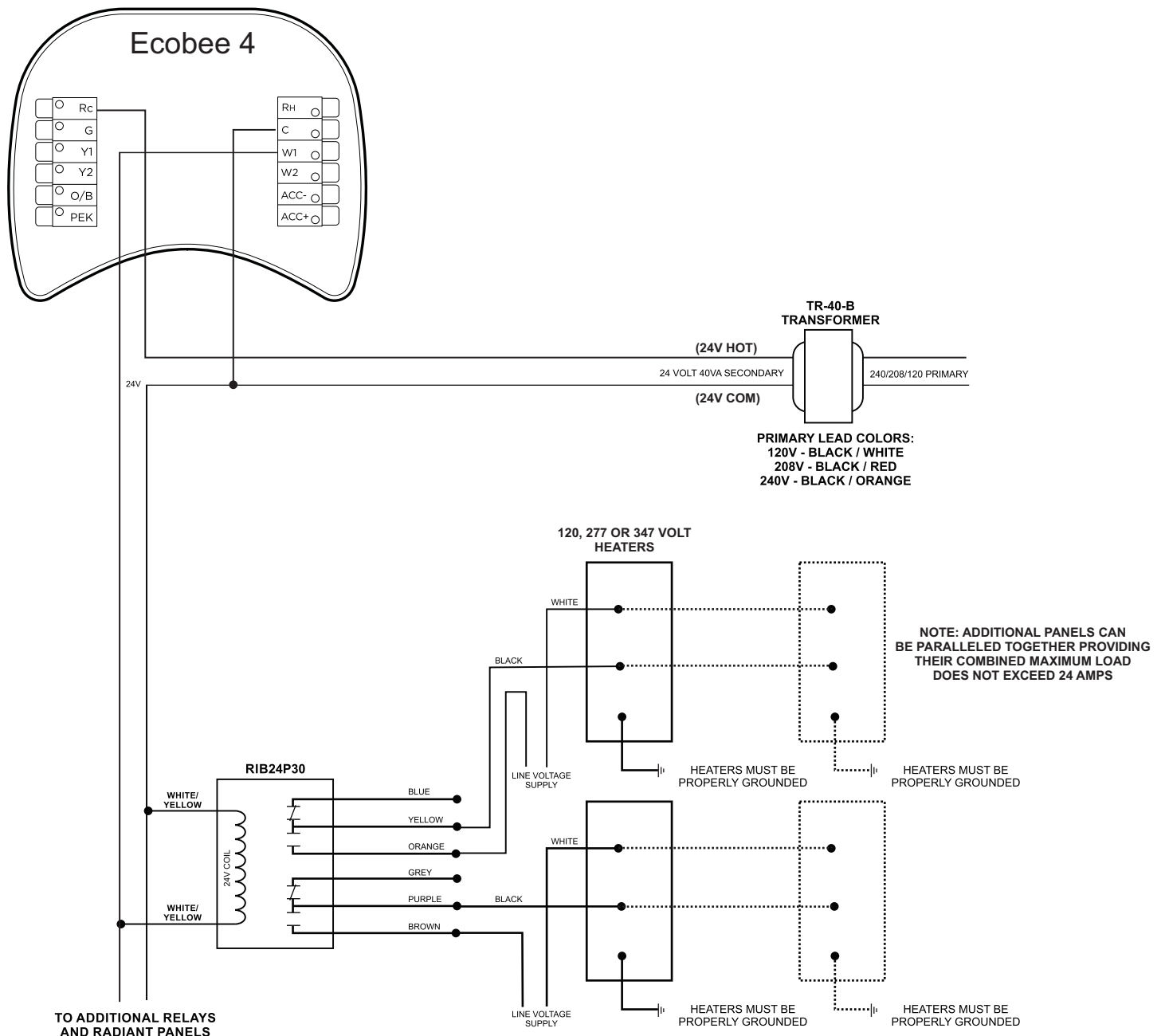

NOTE: 120 Volt CIRCUIT = 2880 vA (Watts) Maximum Load / 24 Amps
 277 Volt CIRCUIT = 6648 vA (Watts) Maximum Load / 24 Amps
 347 Volt CIRCUIT = 8328 vA (Watts) Maximum Load / 24 Amps

208 OR 240 VOLT HEATER WIRING OPTIONS USING 30 AMP RELAY

1. The maximum number of heaters per circuit is limited to circuit wiring and the contact rating of the relay. Always refer to electric radiant ceiling heat panel manufacturer's specifications and wiring diagrams. Wiring diagrams are also available on line at <http://www.heatinggreen.com/thermostat-instructions-wiring-diagrams>
2. The RIBT24P30 relay contacts are rated at 30 Amps @ 300 Volts.
3. Always use a properly grounded junction box when splicing.
4. Install only in a location where the power supply connections will be accessible.
5. Install junction box as far above panel as possible and above building insulation where present.
6. Use field wiring suitable for 194° F (90° C) if junction box is allowed to lie on heater or is enclosed between heater and ceiling above.
7. When installed in a drop ceiling, the wiring terminals should be accessible through removable ceiling sections with adequate clearance to permit access to the top of the heater.

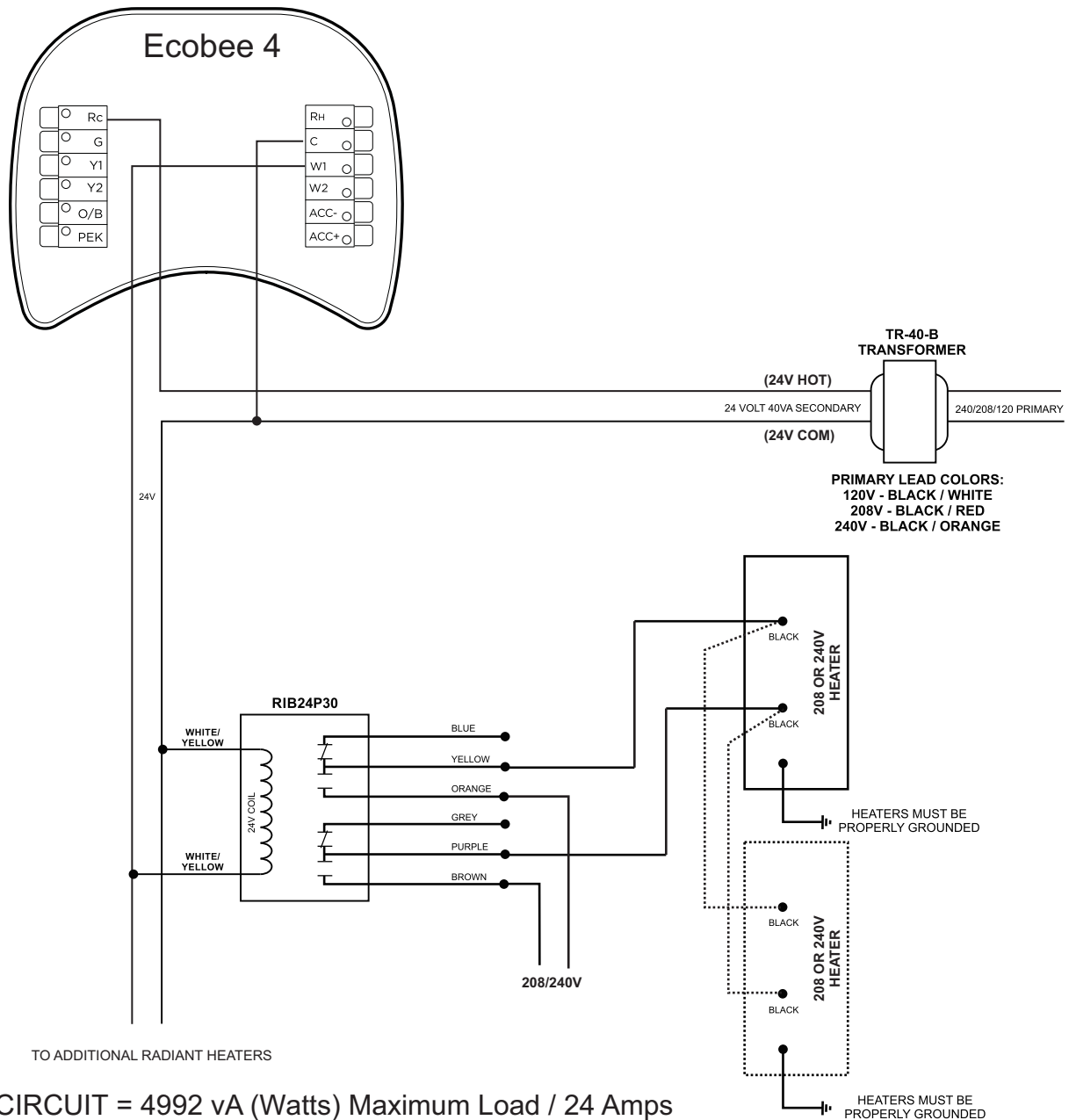

NOTE: 208 Volt CIRCUIT = 4992 vA (Watts) Maximum Load / 24 Amps
 240 Volt CIRCUIT = 5760 vA (Watts) Maximum Load / 24 Amps

TYPICALLY 2-4 HEATERS FIT PER CIRCUIT, DEPENDING ON THE MODEL. PLEASE REFERENCE THE SPECIFICATIONS OF MODEL QUOTED FOR THE PROJECT TO MAKE THIS DETERMINATION